

 **WANSHSIN®** 万鑫精工（湖南）有限公司
WANSHSIN SEIKOU(Hunan) Co.,Ltd

地址：湖南省长沙市宁乡县金洲新区金沙东路158号

Address:No 158,East Jinsha Road,Jinzhou new district,Ningxiang County,
Changsha City,Hunan Province,ChinaSales consultancy/Products
application support

Email:wanshsin@wanshsin.com
Website:www.wanshsin.com

地址：广东省东莞市大岭山镇新塘村连马路1号宏恒景工业园A、B栋

Address:Guang dong dongguan DaLing hills xintang village, even the road
no. 1 macro constant scene industrial park of A and B

Email:wanshsin@wanshsin.com
Website:www.wanshsin.com

 **WANSHSIN®**

致力于打造世界一流的中国传动品牌
We are committed to building a world-class China transmission brand

中型齿轮减速电机

MEDIUM GEAR REDUCING MOTOR

功率：0.1KW-7.5KW

POWER:0.1KW-7.5KW

使用说明书

INSTRUCTION

CE CCC TX



 **WANSHSIN®**
万鑫精工
www.wanshsin.com

使用说明书

欢迎选用万鑫精工系列减速电机(减速机)，本公司集德国设计团队及进口高精度加工设备，得以提供高可靠性及低噪音型减速机。以下为本公司减速机使用说明书及合格证，请详阅以下内容以正确使用减速电机。

产品系列: GH 卧式齿轮减速单/三相电机
 GV 立式齿轮减速单/三相电机
 GHM 卧式直接型齿轮减速机
 GVM 立式直接型齿轮减速机
 GHD 卧式双轴型齿轮减速机
 GVD 立式双轴型齿轮减速机

执行标准:

JB/T9050.1-1999 GB755-2008

1 使用前

- (1) 请检查产品型号、电机功率、电机额定电压、安装方式、减速比及出力轴尺寸是否符合要求，如有不符请及时与厂家或经销商联系，以便及时处理。
- (2) 在减速箱上有胶栓的减速电机(减速机)需将胶栓上面的小胶栓拔掉，否则长时间连续运转后有漏油的危险。

2 使用环境

- (1) 请勿在爆炸环境、易燃性气体环境、腐蚀性环境以及漏水的环境下使用此减速电机。
- (2) 请勿强行弯曲、拉扯或夹住电源、电缆线和电机导线。
- (3) 电机安装完成后，必须使用接地线良好接地，接地线位置位于接线盒上面。
- (4) 安装、连接、检查等须由专业技术人员进行。
- (5) 安装环境需干燥且通风良好，周围温度-5~40°C之间，异常高温或低温时需特别注明。
- (6) 齿轮减速电机需安装在平整且坚固的底座上。

3 电气接线图

● 三相电机/刹车器接线方式

三相六条电机电源线

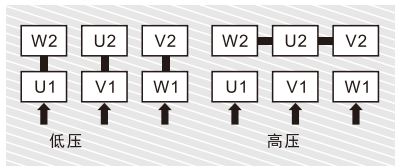

三相六条电机电源线附直流刹车器

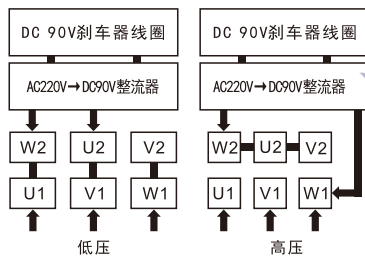

变频器附刹车电机

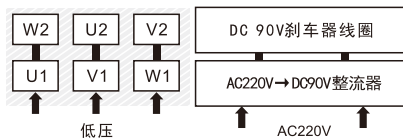

刹车电源与变频器电源需同时开关。

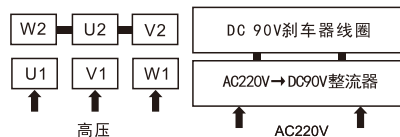

三相九条电机电源线

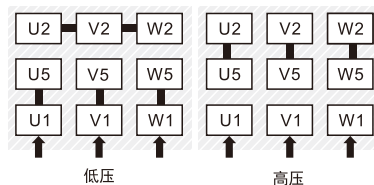

三相九条电机电源线附直流刹车器

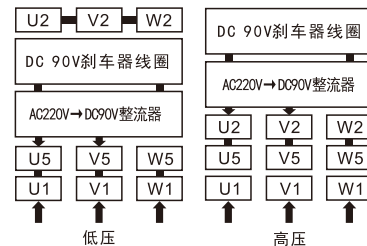

●单相电机/刹车器接线方式

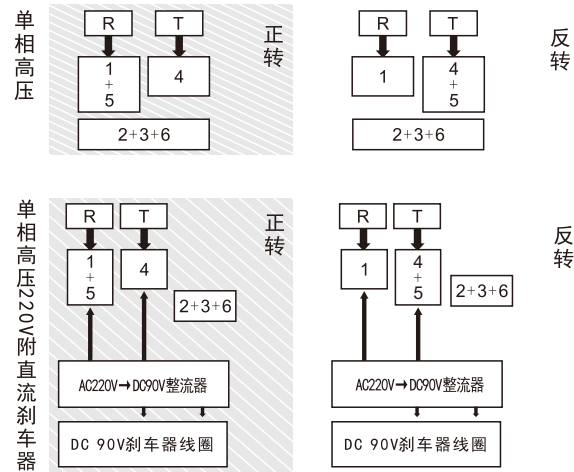
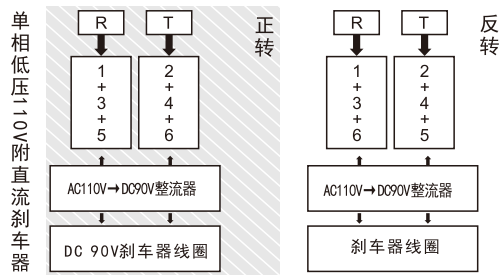
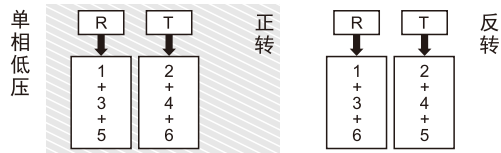

4 安装

- (1) 当使用连轴器连接输出轴时，需安装固定且务必使两轴平行，底座需以安装孔径相适应的螺栓进行安装，确保齿轮减速电机紧密牢固。
- (2) 所有安装在出力轴上的装备必须轻装于轴上，勿使用铁锤及其它钝器等敲击出力轴，避免因安装遇紧而引起轴承损坏。
- (3) 滑轮、链轮或齿轮在装配时尽量靠近出力轴承以减少弯曲应力。应使用不超过出力轴直径6倍的链轮、皮带轮等与出轴连接。使用时请配合H7公差使用，避免使用中发生异常噪音及轴面受损。
- (4) 安装完成后，可以在出力轴表面涂上适当的防锈油或防锈漆以保护出力轴避免生锈。
- (5) 根据电源电压，选择适合的接线方式接好电机线盒内引线，接线盒内接错线会导致电机烧毁。要根据电机铭牌上额定电流，建议 $5A/mm^2$ 的电流密度选择合适尺寸电缆线给电机供电。
- (6) 使用变频器给带刹车功能的齿轮电机供电时，需将刹车线(黄色)单独提供交流220V供电，供电应与齿轮减速电机供电同步。
- (7) 齿轮减速电机齿轮箱内已经加注过足量的润滑油，使用前请勿再次添加润滑油。正常使用超过12000小时后，可加放适合的0号润滑油。
- (8) 安装完成后，再次检查齿轮减速电机安装面是否平整，确保不能有任何物品顶到电机，否则会造成电机烧毁。

5 使用中

- (1) 使用中电源电压变动超过10%时，有可能烧毁电机，同时伴有出力扭矩降低或异常。
- (2) 电机超负荷运行时有可能烧毁，请在运行初次测试电机电流是否在额定电流值内。
- (3) 电机即使在正常运行状态，有时表面温度也会有超过70°C的现象。电机运行时，若有靠近电机的可能请制作“ 高温注意”图标并贴于电机显眼处。
- (4) 电机反转时，单相电机按接线图进行调整，三相电机只需要将电源线两相对调即可。

6 保养与检查

做一般定期检查时，请需注意以下几点：

- (1) 温度上升
 齿轮减速电机为F级绝缘，全密闭外扇构造，所以电机表面温度比周围高50°C左右即属正常。如果温度高于以上时，必须停机检查。（因素：电机或负载传动系统异常）
- (2) 刹车 电机 来令片因长时间使用会有磨损，请依据刹车间隙值进行调整（正常间隙值0.3~0.7mm）。
- (3) 异常振动、噪音
 正常情况，本机几乎没有振动噪音。若有某些安装异常使用，会产生振动噪音，所以请特别留意。（当空载噪音值在70DB/1 M以下时，是被容许的。）
- (4) 电机通风口有时会积聚杂物妨碍通风，所以请清除 电机外部，以确保 电机正常运行温度。
- (5) 定期检查时，请以500V电阻测量电机绕组之绝缘阻抗，确保其1MΩ以上，以避免漏电之危险。

7 故障处理与咨询

(1) 直流刹车器故障排除

不良原因	原因分析	解决方式
刹车器不动作	未供电源	供应电源
	来令片磨损	换新来令片
	间隙过大	调整间隙
	电源电压不足	提供正确电压
	电源供应器损坏	电源供应器换新
	异物入侵	清洁零件
	使用电压错误	使用正确电压
	接线脱落	重新接线
	来令片卡死	清洁零件
	刹车线圈烧毁	更换刹车线圈

刹车移动	来令片磨损	换新来令片
	间隙过大	调整间隙
	来令片沾染油渣	清洁来令片
	负载过大	重新设计
	刹车表面歪斜	更换零件
	下降重量过大	机构重新设计
	选用机型错误	选用正确机型
	环境温度过高	改善环境温度

(2) 减速机故障排除

不良原因		原因分析	解决方式
噪音	齿轮敲击声	齿轮表面受伤	更换受伤齿轮组
	连续性杂音	培林损坏	更换损坏培林
	周期性杂音	异物附着齿面	检查齿轮齿面
	斯斯声	油量不足	添加润滑油
	断续性杂音	润滑油不洁	更换润滑油
振动	固定底座振动	安装平面歪斜	重新调整固定底座
	出力轴振动	培林损坏	更换损害培林
	内部齿轮零件振动	齿轮受伤	更换受伤齿轮
	本体振动	齿轮组安装不良	重新调整齿轮组

漏油	油封漏油	油封硬化	更换损坏油封
	本体漏油	本体有砂孔	更换砂孔本体
	结合面漏油	O型环损坏	更换O型环
过热	油封	油封太紧	更换太紧油封
	本体过热	过负载	重新计算负载马力
	缺润滑油	油量不良	加入润滑油
	电机过热	电机不良	更换新电机

(3) 发生故障时先对照故障排除表进行处理, 不能自行处理的, 请联系经销商或厂家进行解决。

(4) 本机故障, 换用零部件或咨询时, 请将铭牌上的参数确认后再进行联系: 型号、功率、减速比制造编号等。

8 质保

- (1) 本公司同意在正常使用情况下，如有因零件瑕疵或制造不良发生损坏，可于出厂后一年内免费立即维修或以新品更换之。
- (2) 若因客户使用不当，擅自加装配件或自己变更机体等所造成之损坏维修，使用者应自行承担零件维修费用。
- (3) 自然天灾或操作环境恶劣所造成之损坏，虽于保修期内，恕难受理理赔。
- (4) 若无法取得出货日期证明时，以铭牌上制造日期为准。
- (5) 本公司对产品所负责任，不超过产品原如售价。

产品合格证

检验项目

1. 机械性能检验
振动、噪音、减速比、轴跳动、外观质量。
2. 电气性能检验
耐压、匝间绝缘、直流电阻、空载电流、旋转方向。
3. 装箱检验
平键一支、轴套一支、使用说明书及产品合格证一份。

本产品经检验合格准予出厂



Welcome to choose our WANSHSIN gear motor reducer(reducer) , WANSHSIN adopted Germany team and high precision machining equipment to improve the reliability and low noise reducer.The following is the company reducer certificate and instructions,please read the contents of the right to use the reducer motor.

Produce Series:

GH: Horizontal Installation Gear Reducer Single/Three-Phase Motor

GV: Vertical Installation Gear Reducer Single/Three-Phase Motor

GHM: Horizontal Installation Straight Gear Reducer

GVM: Vertical Installation Straight Gear Reducer

GHD: Horizontal Installation Biax Gear Reducer

GVD: Vertical Installation Biax Gear Reducer

Implement Standard:

JB/T9050.1-1999 GB755-2008

Use instructions

1 Before using

- (1) Please check the product type,motor pawar,motor rated voltage,installation,reduction ration,and size of output bearing meet your requirements,if not,please contact your dealer for timely processing.
- (2) For the plastic plugs in the gear boxes.please pull out the yellow small plastic plugs,or else the oil mayspill after long hours of running.

2 Using the environment

- (1) Do not use the gear motor reducer in the environment with explosives,flammable gas,or water leaks.
- (2) Do not forcibly bend,pull or pinch the power supply,cables,and more wires.
- (3) When the motor is installed,it must be grounded properly with a ground wire,which is located on the junction box.
- (4) Installation,connection and inspection must be carried out by professional technicians.
- (5) The installation environment must be dry and well ventilated,the ambient temperature should be-5°C~40°C , and extreme temperatures shall be noted.
- (6) The gear motor reducer should be installed on a flat and solid base.

3 Electrical wiring diagram

• THREE PHASE MOTOR W/BRAKE UNIT DIAGRAM

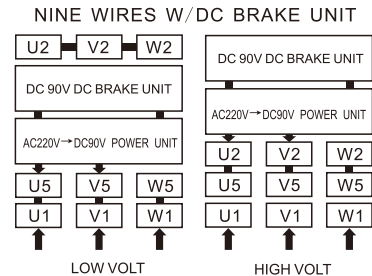
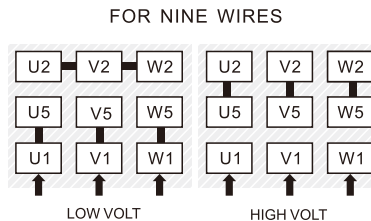
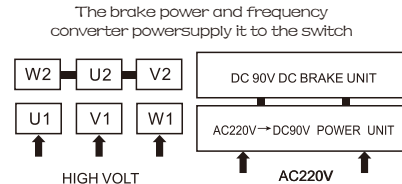
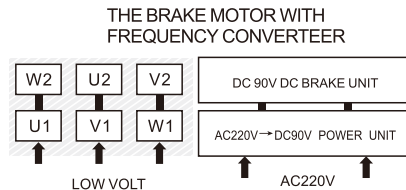
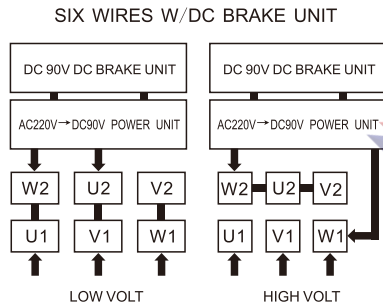
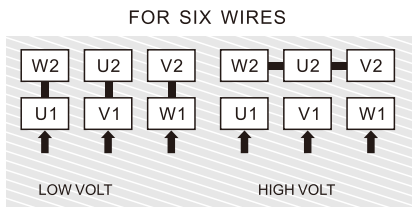

WANSHSIN®
高鑫精工
www.wanshsin.com

• SINGLE PHASE MOTOR W/BRAKE UNIT DIAGRAM

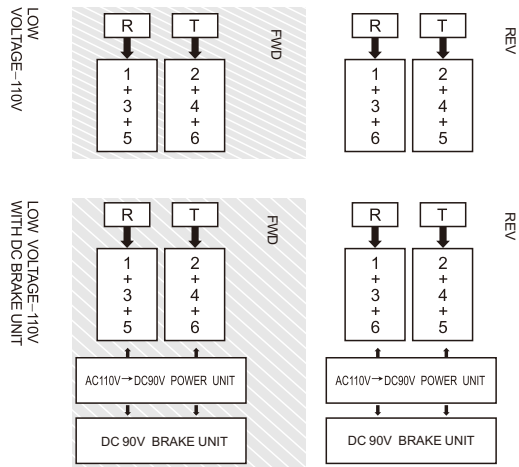

WANSHSIN®
 萬鑫精工
www.wanshsin.com

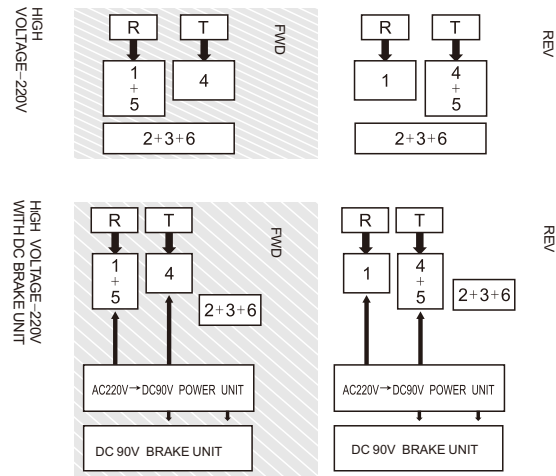

4 INSTALLATION

- (1) When the output bearing is connected with the coupler ,it must be fixed and the two shafts must be parallel,the base should be installed with the bolts of appropriate aperture,and ensure that gear reducer motor is fixed tightly and securely.
- (2) All the equipment installed on the output bearing must be installed lightly; do not knock the output bearing with a hammer or other blunt objects to prevent bearing damage caused by tight installation.
- (3) The pulleys,sprockets and gears should be installed as close as possible to the output bearing to reduce bending stress.Connect to the output bearing through sprocket or belt pulley with a diameter no more than 6 times of the output bearing. Please use in combination with H7 tolerance to avoid noise and damage to the bearing surface.
- (4) After installation,coated suitable anti-rust oil or paint on the surface of the output bearing to avoid rusting.

- (5) Select the proper wiring method to connect the lead wire in the motor connecting junction box with ground wiring according to the power voltage.Wrong wiring of the box will lead to the damage of the motor.According to the rated current on the nameplate of the motor,it is recommended to select the wire of proper size for power supply based on the current density of $5A/mm^2$.
- (6) When the gear reducer motor with brake function is powered by frequency converter, the brake line(yellow) should be provided with AC220V power supply separately, and the power supply should be synchronized with the gear reducer motor.
- (7) THE gear box of the gear reducer motor has been filled with appropriate lubricating oil, and it isn't required to add lubricating use.After normal use for 12,000 hours,add 0# lubricating oil.
- (8) After installation,Check again if the mounting surface of gear reducer motor is flat,and ensure that on objects prop the motor,or else it will cause motor burn.



5 IN USAGE

- (1) If the variation of the supply voltage in use exceeds 10%, the motor might be damaged, accompanied by reduced or abnormal output torque.
- (2) The motor running overload may be burnt. Before running for the first time, test if the motor current is within the rated range.
- (3) Even if the motor is in normal operation state, the surface temperature may also exceed 70. If it is possible to approach the motor when the motor is running, please affix a “ HOT” mark on a conspicuous place on the motor.
- (4) When the motor is running reversely, Adjust single-phase motor according to the wiring diagram. For three-phase motors, just exchange two phases of the power cable.



6 MAINTENANCE AND INSPECTION

Please pay attention to the following points during the general periodical inspection

- (1) Temperature rise
The gear motor of Grade F insulation, is a fully enclosed outer fan structure, it is normal that the temperature of the motor is about 50°C higher than the ambient temperature. When the temperature exceeds 50°C, the machine must be stopped for inspection. (factor: abnormal load of motor or transmission system)
- (2) As the lining of the motor abrades due to long-term use, please adjust it according to the brake clearance. (normal brake clearance is 0.3~0.7mm)
- (3) Abnormal vibration and noise
There is almost no noise in normal situations. If there is abnormal installation, it will vibrate with noise, so please pay attention to it. (It is tolerable when the idling)
- (4) Sometime there will be accumulated debris hindering ventilation on motor vents, so please clear outside of the motor, to ensure the normal operation of the motor temperature.
- (5) Please Periodically check the insulation resistance of the motor winding with 500V resistance to ensure that it is more than 1MΩ to avoid the risk of leakage.

7 TROUBLESHOOTING AND CONSULTING

(1) TROUBLE SHOOTING FOR DC BRAKE UNIT

DEFECTIVE REASON	POSSIBLE ANALYSIS	SOLUTION METHOD
NO ACTION	NO POWER INSIDE BRAKE	SUPPLY POWER
	BRAKE DISC WORN OUT	USE NEW BRAKE DISC
	LARGE CLEARANCE	ADJUST CLEARANCE
	LOW VOLTAGE	USE CORRECT VOLTAGE
	POWER SUPPLY DAMAGE	ADJUST CLEARANCE
	DIRTY INSIDE	CLEAN PARTS

NO ACTION	WRONG VOLTAGE	CORRECT VOLTAGE
	CONNECT WIRE LOST	RE-CONNECT WIRE
	BRAKE DISC LOCKED	CLEAN PARTS
	BRAKE COIL BURNED-OUT	USE NEW BRAKE COIL
OVER STOP	BRAKE DISC WORN OUT	USE NEW BRAKE DISC
	LARGE CLEARANCE	ADJUST CLEARANCE
	SURFACE WORN	CLEAN BRAKE DISC
	OVER LOADING	RE-DESIGN BRAKE UNIT
	DISC SURFACE TWIST	USE NEW PARTS
	HUGE MOMENTUM	SYSTEM RE-DESIGN
	SELECT WRONG TYPE	RE-SELECT UNIT
	HIGH TEMPERATURE	ADJUST TEMPERATURE

(2) TROUBLE SHOOTING FOR GEARMOTOR

	DEFECTIVE REASON	POSSIBLE ANALYSIS	SOLUTION METHOD
NOISE	KNOCKING	HURT GEAR SURFACE	REPLACE GEAR SFT
	CONTINUALLY	BAD BEARING	REPLACE BEARING
	PERIODICALLY	PARTICLE INSIDE	CHECK GEAR
	NEIGH	HURT GEAR SURFACE	REPLACE GEAR SFT
	INTERMITTENTLY	DIRTY LUBRICANT	FILL WITH LUB--OIL
VIBRATING	MOUNTING BASE M	BAD SURFACE MOUNTIN	E-ADJUST MOUNTING BASE
	OUTPUT SHAFT MOVING	BEARING BROKEN	REPLACE WOUNDED BRARING
	INSIDE GEAR PARTS MOVEMENT	GEAR WOUNDED	REPLACE WOUNDED BEARING
	HOUSING VIBRATING	BAD GEAR ASSEMBLY	RE-ADJUST GEAB SET

LEAKAGE	OIL SEAL LEAKAGE	OIL SEAL TOO HARDEN	REPLACE WOUNDED OIL SEAL
	HOUSING LEAKAGE	HOUSING HAD SAND HOLE	REPLACE SAND HOLE HOUSING
	CONNECT SURFAXE LEAKAGE	ORINGBR	REPLACE WOUNDED ORING
OVER-HEATING	BAD OIL SEAL	OIL SEAL TOO TIGHT	REPLACE TIGHTEN OIL SEAL
	HOUSING TOO HEAT	OVER LOAD RUNNING	RE—CALAULATE LOADING
	IESS IUBRICANT	LACK OF LUBRICANT	FILL WITH LUBRICANT
	MOTOR TOO HEAT	DEFECTIVE MOTOR	REPLACE NEW MOTOR

(3) In case of the failure, please check the troubleshooting table firstly. If the fault can not be handed by itself please contact the dealer or the manufacturer for soluti on.

(4) In case of failure, when you change the parts or consult, please confirm the parameters on the nameplate, and then contact as following: Type, Power, Output ratio, manufac turing number and so on.

8 QUALITY WARRANTY.

- (1) Under company agrees using conditions, if there are defective parts or manufacturing damage Occurred, it can be repaired free of charge or replaced by new products within one year after shipped.
- (2) If the customer improper use, unauthorized installation of parts or change the body caused by Damage to the maintenance the user should bear the cost of spare parts maintenance.
- (3) Natural disasters or poor operating environment caused by the damage. though in the warranty period WANSHSIN can accept the claim.
- (4) If you can not obtain proof of shipment date the nameplate date of manufacture shall prevail.
- (5) WANSHSIN is responsible for the product within the original sale-price inspection item.

Product Qualification Certificate

Inspection item

1. Mechanical Performance Inspection

vibrate, Noise, Reduction, Ratio, Shaft runout, Appearance Quality

2. Electrical Performance Inspection

Pressure, Inter-turn insulation, DC Resistance, No-load Current, Turn direction

3. Packing Inspection

One key, one shaft sleeve, Instruction and product qualification certificate

This product has been inspected and qualified to leave the factory

